

INVERTEC®

V205-T AC/DC & V305-T AC/DC

OPERATOR'S MANUAL



LINCOLN®
ELECTRIC

LINCOLN ELECTRIC ITALIA S.r.l
Via Fratelli Canepa 8, 16010 Serrà Riccò (GE), Italia
www.lincolnelectric.eu

Declaration of conformity
Dichiarazione di conformità
Konformitätserklärung
Declaración de conformidad
Déclaration de conformité
Samsvars erklæring
Verklaring van overeenstemming

Försäkran om överensstämmelse
Deklaracja zgodności
Vakuutus yhteensopivuudesta

LINCOLN ELECTRIC ITALIA S.r.l.



Declares that the welding machine:
Dichiara che il generatore per saldatura tipo:
Erklärt, daß die Bauart der Maschine:
Declara que el equipo de soldadura:
Déclare que le poste de soudage:
Bekrefter at denne sveisemaskin:
Verklaart dat de volgende lasmachine:

Försäkrar att svetsomriktaren:
Deklaruje, że spawalnicze źródło energii:
Vakuuttaa, että hitsauskone:

INVERTEC[®] V205-T AC/DC

conforms to the following directives:
è conforme alle seguenti direttive:
den folgenden Bestimmungen entspricht:
es conforme con las siguientes directivas:
est conforme aux directives suivantes:
er i samsvar med følgende direktiver:
overeenkomt conform de volgende richtlijnen:

överensstämmer med följande direktiv:
spełnia następujące wytyczne:
täyttää seuraavat direktiivit:

73/23/CEE, 89/336/CEE

and has been designed in compliance with the following standards:
ed è stato progettato in conformità alle seguenti norme:
und in Übereinstimmung mit den nachstehenden normen hergestellt wurde:
y ha sido diseñado de acuerdo con las siguientes normas:
et qu'il a été conçu en conformité avec les normes:
og er produsert og testet iht. følgende standarder:

en is ontworpen conform de volgende normen:
och att den konstruerats i överensstämmelse med följande standarder:
i że zostało zaprojektowane zgodnie z wymaganiami następujących norm:
ja on suunniteltu seuraavien standardien mukaan:

EN 60974-1, EN 60974-10

(2002)

Dario Gatti
European Engineering Director Machines
LINCOLN ELECTRIC ITALIA S.r.l., Via Fratelli Canepa 8, 16010 Serra Riccò (GE), Italia

Declaration of conformity
Dichiarazione di conformità
Konformitätserklärung
Declaración de conformidad
Déclaration de conformité
Samsvars erklæring
Verklaring van overeenstemming

Försäkran om överensstämmelse
Deklaracja zgodności
Vakuutus yhteensopivuudesta

LINCOLN ELECTRIC ITALIA S.r.l.



Declares that the welding machine:
Dichiara che Il generatore per saldatura tipo:
Erklärt, daß die Bauart der Maschine:
Declara que el equipo de soldadura:
Déclare que le poste de soudage:
Bekrefter at denne sveisemaskin:
Verklaart dat de volgende lasmachine:

Försäkrar att svetsomriktaren:
Deklaruje, że spawalnicze źródło energii:
Vakuuttaa, että hitsauskone:

INVERTEC[®] V305-T AC/DC

conforms to the following directives:
è conforme alle seguenti direttive:
den folgenden Bestimmungen entspricht:
es conforme con las siguientes directivas:
est conforme aux directives suivantes:
er i samsvar med følgende direktiver:
overeenkomt conform de volgende richtlijnen:

överensstämmer med följande direktiv:
spełnia następujące wytyczne:
täyttää seuraavat direktiivit:

73/23/CEE, 89/336/CEE







and has been designed in compliance with the following standards:
ed è stato progettato in conformità alle seguenti norme:
und in Übereinstimmung mit den nachstehenden normen hergestellt wurde:
y ha sido diseñado de acuerdo con las siguientes normas:
et qu'il a été conçu en conformité avec les normes:
og er produsert og testet iht. følgende standarder:

en is ontworpen conform de volgende normen:
och att den konstruerats i överensstämmelse med följande standarder:
i że zostało zaprojektowane zgodnie z wymaganiami następujących norm:
ja on suunniteltu seuraavien standardien mukaan:

EN 60974-1, EN 60974-10

(2002)

Dario Gatti
European Engineering Director Machines
LINCOLN ELECTRIC ITALIA S.r.l., Via Fratelli Canepa 8, 16010 Serra Riccò (GE), Italia

English		<p>Do not dispose of electrical equipment together with normal waste! In observance of European Directive 2002/96/EC on Waste Electrical and Electronic Equipment (WEEE) and its implementation in accordance with national law, electrical equipment that has reached the end of its life must be collected separately and returned to an environmentally compatible recycling facility. As the owner of the equipment, you should get information on approved collection systems from our local representative. By applying this European Directive you will protect the environment and human health!</p>
Italiano		<p>Non gettare le apparecchiature elettriche tra i rifiuti domestici! In ottemperanza alla Direttiva Europea 2002/96/CE sui Rifiuti di Apparecchiature Elettriche ed Elettroniche (RAEE) e la sua attuazione in conformità alle norme nazionali, le apparecchiature elettriche esauste devono essere raccolte separatamente e restituite ad una organizzazione di riciclaggio ecocompatibile. Come proprietario dell'apparecchiatura, Lei potrà ricevere informazioni circa il sistema approvato di raccolta, dal nostro rappresentante locale. Applicando questa Direttiva Europea Lei contribuirà a migliorare l'ambiente e la salute!</p>
Deutsch		<p>Werfen Sie Elektrowerkzeuge nicht in den Hausmüll! Gemäss Europäischer Richtlinie 2002/96/EG über Elektro- und Elektronik- Altgeräte (Waste Electrical and Electronic Equipment, WEEE) und Umsetzung in nationales Recht müssen verbrauchte Elektrowerkzeuge getrennt gesammelt und einer umweltgerechten Wiederverwertung zugeführt werden. Als Eigentümer diese Werkzeuges sollten sie sich Informationen über ein lokales autorisiertes Sammel- bzw. Entsorgungssystem einholen. Mit der Anwendung dieser EU Direktive tragen sie wesentlich zur Schonung der Umwelt und ihrer Gesundheit bei!</p>
Español		<p>No tirar nunca los aparatos eléctricos junto con los residuos en general! De conformidad a la Directiva Europea 2002/96/EC relativa a los Residuos de Equipos Eléctricos o Electrónicos (RAEE) y al acuerdo de la legislación nacional, los equipos eléctricos deberán ser recogidos y reciclados respetando el medioambiente. Como propietario del equipo, deberá informar de los sistemas y lugares apropiados para la recogida de los mismos. Aplicar esta Directiva Europea protegerá el medioambiente y su salud!</p>
Français		<p>Ne pas jeter les appareils électriques avec les déchets ordinaires! Conformément à la Directive Européenne 2002/96/EC relative aux Déchets d' Équipements Électriques ou Électroniques (DEEE), et à sa transposition dans la législation nationale, les appareils électriques doivent être collectés à part et être soumis à un recyclage respectueux de l'environnement. En tant que propriétaire de l'équipement, vous devriez vous informer sur les systèmes de collecte approuvés auprès nos représentants locaux. Appliquer cette Directive Européenne améliorera l'environnement et la santé!</p>
Norsk		<p>Kast ikke elektriske artikler sammen med vanlig søppel. I følge det europeiske direktivet for Elektronisk Søppel og Elektriske Artikler 2002/96/EC (Waste Electrical and Electronic Equipment, WEEE) skal alt avfall kildesorteres og leveres på godkjente plasser i følge loven. Godkjente retur plasser gis av lokale myndigheter. Ved å følge det europeiske direktivet bidrar du til å bevare naturen og den menneskelige helse.</p>
Nederlandse		<p>Gooi elektrische apparatuur nooit bij gewoon afval! Met inachtneming van de Europese Richtlijn 2002/96/EC met betrekking tot Afval van Elektrische en Elektronische Apparatuur (Waste Electrical and Electronic Equipment, WEEE) en de uitvoering daarvan in overeenstemming met nationaal recht, moet elektrische apparatuur, waarvan de levensduur ten einde loopt, apart worden verzameld en worden ingeleverd bij een recycling bedrijf, dat overeenkomstig de milieuwetgeving opereert. Als eigenaar van de apparatuur moet u informatie inwinnen over goedgekeurde verzamelingsystemen van onze vertegenwoordiger ter plaatse. Door het toepassen van deze Europese Richtlijn beschermt u het milieu en ieders gezondheid!</p>
Svenska		<p>Släng inte uttjänt elektrisk utrustning tillsammans med annat avfall! Enligt Europadirektiv 2002/96/EC ang. Uttjänt Elektrisk och Elektronisk Utrustning (Waste Electrical and Electronic Equipment, WEEE) och dess implementering enligt nationella lagar, ska elektrisk utrustning som tjänat ut sorteras separat och lämnas till en miljögodkänd återvinningsstation. Som ägare till utrustningen, bör du skaffa information om godkända återvinningsssystem från dina lokala myndigheter. Genom att följa detta Europadirektiv bidrar du till att skydda miljö och hälsa!</p>
Polski		<p>Nie wyrzucać sprzętu elektrycznego razem z normalnymi odpadami! Zgodnie z Dyrektywą Europejską 2002/96/EC dotyczącą Pozbywania się zużytego Sprzętu Elektrycznego i Elektronicznego (Waste Electrical and Electronic Equipment, WEEE) i jej wprowadzeniem w życie zgodnie z międzynarodowym prawem, zużyty sprzęt elektryczny musi być składowany oddzielnie i specjalnie utylizowany. Jako właściciel urządzeń powinniście otrzymać informacje o zatwierdzonym systemie składowania od naszego lokalnego przedstawiciela. Stosując te wytyczne bedziesz chronił środowisko i zdrowie człowieka!</p>
Suomi		<p>Älä hävittää sähkölaitteita sekajätteiden mukana! Noudatettaessa Euroopan Unionin Direktiiviä 2002/96/EY Sähkölaite- ja Elektroniikkajätteestä (WEEE) ja toteutettaessa sitä sopuosinussa kansallisen lain kanssa, sähkölaite, joka on tullut elinkaarensa päähän pitää kerätä erilleen ja toimittaa sähkö- ja elektroniikkaromujen keräyspisteeseen. Lisätietoja tämän tuotteen käsittelystä, keräämisestä ja kierrätyksestä saa kunnan ympäristöviranomaisilta. Noudattamalla tätä Euroopan Unionin direktiiviä, autat torjumaan kielteiset ympäristö- ja terveysvaikutukset!</p>

<p>THANKS! For having chosen the QUALITY of the Lincoln Electric products.</p> <ul style="list-style-type: none"> Please Examine Package and Equipment for Damage. Claims for material damaged in shipment must be notified immediately to the dealer. For future reference record in the table below your equipment identification information. Model Name, Code & Serial Number can be found on the machine rating plate.
<p>GRAZIE! Per aver scelto la QUALITÀ dei prodotti Lincoln Electric.</p> <ul style="list-style-type: none"> Esamini l'imballo ed Equipaggiamento per rilevare eventuali danneggiamenti. Le richieste per materiali danneggiati dal trasporto devono essere immediatamente notificate al rivenditore. Per ogni futuro riferimento, compilare la tabella sottostante con le informazioni di identificazione equipaggiamento. Modello, Codice (Code) e Matricola (Serial Number) sono reperibili sulla targa dati della macchina.
<p>VIELEN DANK! Dass Sie sich für ein QUALITÄTSPRODUKT von Lincoln Electric entschieden haben.</p> <ul style="list-style-type: none"> Bitte überprüfen Sie die Verpackung und den Inhalt auf Beschädigungen. Transportschäden müssen sofort dem Händler gemeldet werden. Damit Sie Ihre Gerätedaten im Bedarfsfall schnell zur Hand haben, tragen Sie diese in die untenstehende Tabelle ein. Typenbezeichnung, Code- und Seriennummer finden Sie auf dem Typenschild Ihres Gerätes.
<p>GRACIAS! Por haber escogido los productos de CALIDAD Lincoln Electric.</p> <ul style="list-style-type: none"> Por favor, examine que el embalaje y el equipo no tengan daños. La reclamación del material dañado en el transporte debe ser notificada inmediatamente al proveedor. Para un futuro, a continuación encontrará la información que identifica a su equipo. Modelo, Code y Número de Serie los cuales pueden ser localizados en la placa de características de su equipo.
<p>MERCI! Pour avoir choisi la QUALITÉ Lincoln Electric.</p> <ul style="list-style-type: none"> Vérifiez que ni l'équipement ni son emballage ne sont endommagés. Toute réclamation pour matériel endommagé doit être immédiatement notifiée à votre revendeur. Notez ci-dessous toutes les informations nécessaires à l'identification de votre équipement. Le nom du Modèle ainsi que les numéros de Code et Série figurent sur la plaque signalétique de la machine.
<p>TAKK! For at du har valgt et KVALITETSPRODUKT fra Lincoln Electric.</p> <ul style="list-style-type: none"> Kontroller emballsjen og produktet for feil eller skader. Eventuelle feil eller transportskader må umiddelbart rapporteres dit du har kjøpt din maskin. For fremtidig referanse og for garantier og service, fyll ut den tekniske informasjonen nedenfor i dette avsnittet. Modell navn, Kode & Serie nummer finner du på den tekniske platen på maskinen.
<p>BEDANKT! Dat u gekozen heeft voor de KWALITEITSPRODUCTEN van Lincoln Electric.</p> <ul style="list-style-type: none"> Controleert u de verpakking en apparatuur op beschadiging. Claims over transportschade moeten direct aan de dealer of aan Lincoln electric gemeld worden. Voor referentie in de toekomst is het verstandig hieronder u machinegegevens over te nemen. Model Naam, Code & Serienummer staan op het typeplaatje van de machine.
<p>TACK! För att ni har valt en KVALITETSPRODUKT från Lincoln Electric.</p> <ul style="list-style-type: none"> Vänligen kontrollera förpackning och utrustning m.a.p. skador. Transportskador måste omedelbart anmälas till återförsäljaren eller transportören. Notera informationen om er utrustnings identitet i tabellen nedan. Modellbeteckning, code- och serienummer hittar ni på maskinens märkplåt.
<p>DZIĘKUJEMY! Za docenienie JASKOŚCI produktów Lincoln Electric.</p> <ul style="list-style-type: none"> Proszę sprawdzić czy opakownie i sprzęt nie są uszkodzone. Reklamacje uszkodzeń powstałych podczas transportu muszą być natychmiast zgłoszone do dostawcy (dystrybutora). Dla ułatwienia prosimy o zapisanie na tej stronie danych identyfikacyjnych wyrobów. Nazwa modelu, Kod i Numer Seryjny, które możecie Państwo znaleźć na tabliczce znamionowej wyrobu.
<p>KIITOS! Kiitos, että olet valinnut Lincoln Electric LAATU tuotteita.</p> <ul style="list-style-type: none"> Tarkista pakkaus ja tuotteet vaurioiden varalta. Vaateet mahdollisista kuljetusvaurioista on ilmoitettava välittömästi jälleenmyyjälle. Tulevaisuutta varten täytä alla oleva lomake laitteen tunnistusta varten. Mallin, Koodin ja Sarjanumeron voit löytää konekilvestä.

<p>Model Name, Modello, Typenbezeichnung, Modelo, Nom du modèle, Modell navn, Model Naam, Modellbeteckning, Nazwa modelu, Mallinimi:</p> <p>.....</p>
<p>Code & Serial number, Code (codice) e Matricola, Code- und Seriennummer, Code y Número de Serie, Numéros de Code et Série, Kode & Serie nummer, Code en Serienummer, Code- och Serienummer, Kod i numer Seryjny, Koodi ja Sarjanumero:</p> <p>.....</p>
<p>Date & Where Purchased, Data e Luogo d'acquisto, Kaufdatum und Händler, Fecha y Nombre del Proveedor, Lieu et Date d'acquisition, Kjøps dato og Sted, Datum en Plaats eerste aankoop, Inköpsdatum och Inköpsställe, Data i Miejsce zakupu, Päiväys ja Ostopaikka:</p> <p>.....</p>

ENGLISH INDEX

Safety	A-1
Installation and Operator Instructions	A-2
Electromagnetic Compatibility (EMC)	A-6
Technical Specifications	A-7

INDICE ITALIANO

Sicurezza	B-1
Installazione e Istruzioni Operative	B-2
Compatibilità Elettromagnetica (EMC)	B-7
Specifiche Tecniche	B-7

INHALTSVERZEICHNIS DEUTSCH

Sicherheitsmaßnahmen / Unfallschutz	C-1
Installation und Bedienungshinweise	C-2
Elektromagnetische Verträglichkeit (EMC)	C-7
Technische Daten	C-8

INDICE ESPAÑOL

Seguridad	D-1
Instalación e Instrucciones de Funcionamiento	D-2
Compatibilidad Electromagnética (EMC)	D-7
Especificaciones Técnicas	D-7

INDEX FRANÇAIS

Sécurité	E-1
Installation et Instructions d'Utilisation	E-2
Compatibilité Electromagnétique (CEM)	E-6
Caractéristiques Techniques	E-7

NORSK INNHOLDSFORTEGNELSE

Sikkerhetsregler	F-1
Installasjon og Brukerinstruksjon	F-2
Elektromagnetisk Kompatibilitet (EMC)	F-7
Tekniske Spesifikasjoner	F-7

NEDERLANDSE INDEX

Veiligheid	G-1
Installatie en Bediening	G-2
Elektromagnetische Compatibiliteit (EMC)	G-6
Technische Specificaties	G-7

SVENSK INNEHÅLLSFÖRTECKNING

Säkerhetsanvisningar	H-1
Instruktioner för Installation och Handhavande	H-2
Elektromagnetisk Kompatibilitet (EMC)	H-6
Tekniska Specifikationer	H-7

SKOROWIDZ POLSKI

Bezpieczeństwo Użytkowania	I-1
Instrukcja Instalacji i Eksploatacji	I-2
Kompatybilność Elektromagnetyczna (EMC)	I-7
Dane Techniczne	I-8

SISÄLLYSLUETTELO

Turvallisuus	J-1
Asennus ja Käyttöohjeet	J-2
Elektromagneettinen Yhteensopivuus (EMC)	J-6
Tekniset Tiedot	J-6



Spare Parts, Parti di Ricambio, Ersatzteile, Lista de Piezas de Recambio, Pièces de Rechange, Deleliste, Reserve Onderdelen, Reservdelar, Wykaz Części Zamiennych, Varaosaluettelo	1
Electrical Schematic, Schema Elettrico, Elektrische Schaltpläne, Esquema Eléctrico, Schéma Electrique, Elektrisk Skjema, Elektrisk Schema, Elektriskt Kopplingschema, Schemat Elektryczny, Sähkökaavio	6
Accessories, Accessori, Zubehör, Accesorios, Accessoires, Tilleggsutstyr, Accesorios, Tillbehör, Akcesoria, Varusteet	8



WARNING

This equipment must be used by qualified personnel. Be sure that all installation, operation, maintenance and repair procedures are performed only by qualified person. Read and understand this manual before operating this equipment. Failure to follow the instructions in this manual could cause serious personal injury, loss of life, or damage to this equipment. Read and understand the following explanations of the warning symbols. Lincoln Electric is not responsible for damages caused by improper installation, improper care or abnormal operation.

	<p>WARNING: This symbol indicates that instructions must be followed to avoid serious personal injury, loss of life, or damage to this equipment. Protect yourself and others from possible serious injury or death.</p>
	<p>READ AND UNDERSTAND INSTRUCTIONS: Read and understand this manual before operating this equipment. Arc welding can be hazardous. Failure to follow the instructions in this manual could cause serious personal injury, loss of life, or damage to this equipment.</p>
	<p>ELECTRIC SHOCK CAN KILL: Welding equipment generates high voltages. Do not touch the electrode, work clamp, or connected work pieces when this equipment is on. Insulate yourself from the electrode, work clamp, and connected work pieces.</p>
	<p>ELECTRICALLY POWERED EQUIPMENT: Turn off input power using the disconnect switch at the fuse box before working on this equipment. Ground this equipment in accordance with local electrical regulations.</p>
	<p>ELECTRICALLY POWERED EQUIPMENT: Regularly inspect the input, electrode, and work clamp cables. If any insulation damage exists replace the cable immediately. Do not place the electrode holder directly on the welding table or any other surface in contact with the work clamp to avoid the risk of accidental arc ignition.</p>
	<p>ELECTRIC AND MAGNETIC FIELDS MAY BE DANGEROUS: Electric current flowing through any conductor creates electric and magnetic fields (EMF). EMF fields may interfere with some pacemakers, and welders having a pacemaker shall consult their physician before operating this equipment.</p>
	<p>CE COMPLIANCE: This equipment complies with the European Community Directives.</p>
	<p>FUMES AND GASES CAN BE DANGEROUS: Welding may produce fumes and gases hazardous to health. Avoid breathing these fumes and gases. To avoid these dangers the operator must use enough ventilation or exhaust to keep fumes and gases away from the breathing zone.</p>
	<p>ARC RAYS CAN BURN: Use a shield with the proper filter and cover plates to protect your eyes from sparks and the rays of the arc when welding or observing. Use suitable clothing made from durable flame-resistant material to protect you skin and that of your helpers. Protect other nearby personnel with suitable, non-flammable screening and warn them not to watch the arc nor expose themselves to the arc.</p>
	<p>WELDING SPARKS CAN CAUSE FIRE OR EXPLOSION: Remove fire hazards from the welding area and have a fire extinguisher readily available. Welding sparks and hot materials from the welding process can easily go through small cracks and openings to adjacent areas. Do not weld on any tanks, drums, containers, or material until the proper steps have been taken to insure that no flammable or toxic vapors will be present. Never operate this equipment when flammable gases, vapors or liquid combustibles are present.</p>
	<p>WELDED MATERIALS CAN BURN: Welding generates a large amount of heat. Hot surfaces and materials in work area can cause serious burns. Use gloves and pliers when touching or moving materials in the work area.</p>
	<p>SAFETY MARK: This equipment is suitable for supplying power for welding operations carried out in an environment with increased hazard of electric shock.</p>

	EQUIPMENT WEIGHT OVER 30kg: Move this equipment with care and with the help of another person. Lifting may be dangerous for your physical health.
	CYLINDER MAY EXPLODE IF DAMAGED: Use only compressed gas cylinders containing the correct shielding gas for the process used and properly operating regulators designed for the gas and pressure used. Always keep cylinders in an upright position securely chained to a fixed support. Do not move or transport gas cylinders with the protection cap removed. Do not allow the electrode, electrode holder, work clamp or any other electrically live part to touch a gas cylinder. Gas cylinders must be located away from areas where they may be subjected to physical damage or the welding process including sparks and heat sources.
HF	CAUTION: The high frequency used for contact-free ignition with TIG (GTAW) welding, can interfere with the operation of insufficiently shielded computer equipment, EDP centers and industrial robots, even causing complete system breakdown. TIG (GTAW) welding may interfere with electronic telephone networks and with radio and TV reception.

Installation and Operator Instructions

Read this entire section before installation or operation of the machine.

Location and Environment

This machine will operate in harsh environments. However, it is important that simple preventative measures are followed to assure long life and reliable operation.

- Do not place or operate this machine on a surface with an incline greater than 15° from horizontal.
- Do not use this machine for pipe thawing.
- This machine must be located where there is free circulation of clean air without restrictions for air movement to and from the air vents. Do not cover the machine with paper, cloth or rags when switched on.
- Dirt and dust that can be drawn into the machine should be kept to a minimum.
- This machine has a protection rating of IP23S. Keep it dry when possible and do not place it on wet ground or in puddles.
- Locate the machine away from radio controlled machinery. Normal operation may adversely affect the operation of nearby radio controlled machinery, which may result in injury or equipment damage. Read the section on electromagnetic compatibility in this manual.
- Do not operate in areas with an ambient temperature greater than 40°C.

Input Supply Connection

Check the input voltage, phase, and frequency supplied to this machine before turning it on. The allowable input voltage is indicated in the technical specification section of this manual and on the rating plate of the machine. Verify the connection of grounding wires from the machine to the input source.

Make sure the amount of power available from the input connection is adequate for normal operation of the machine. The necessary fuse and cable sizes are indicated in the technical specification section of this manual.

The V205-T AC/DC is machine is designed to operate on engine driven generators as long as the 230Vac auxiliary can supply adequate power as indicated in the

technical specification section of this manual. The auxiliary supply of the generator must also meet the following conditions.

- The AC waveform peak voltage is below 410V.
- The AC waveform frequency is between 50 and 60 Hz.
- The RMS voltage of the AC waveform is always equal to 230Vac ± 15%.

It is important to check these conditions because many engine driven generators produce high voltage spikes. Operation of this machine on engine driven generators not conforming to these conditions is not recommended and may damage the machine.

Output Connections

A quick disconnect system using Twist-Mate cable plugs is used for the welding cable connections. Refer to the following sections for more information on connecting the machine for operation of stick welding (MMA) or TIG welding (GTAW).

Stick Welding (MMA)

First determine the proper electrode polarity for the electrode to be used. Consult the electrode data for this information. Then connect the output cables to the output terminals of the machine for the selected polarity. For example, if DC(+) welding will be used then connect the electrode cable to the (+) terminal of the machine and the work clamp to the (-) terminal. Insert the connector with the key lining up with the keyway and rotate approximately ¼ turn clockwise. Do not over tighten.

For DC(-) welding switch the cable connections at the machine so that the electrode cable is connected to (-) and the work clamp is connected to (+).

TIG Welding (GTAW)

This machine does not include a TIG torch necessary for TIG welding, but one may be purchased separately. Refer to the accessories section for more information. Connect the torch cable to the (-) terminal of the machine and the work clamp to the (+) terminal. Insert the connector with the key lining up with the keyway and rotate approximately ¼ turn clockwise. Do not over tighten.

Connect the gas hose from the TIG torch to the gas connector (B) on the front of the machine. If necessary, an extra gas connector for the fitting on the front of the machine is included in the package. Next, connect the fitting on the back of the machine to a gas regulator on the cylinder of gas to be used. An input gas line and the required fittings are also included in the package. Connect the TIG torch trigger to the trigger connector (A) on the front of the machine. Connect the water hoses to the water connectors on the front of the Coolarc if the machine is completed with a Coolarc water-cooler.

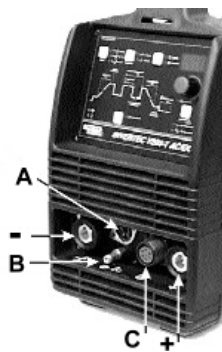

Remote Control Connection

Refer to the accessories section for a list of remote controls. If a remote control is used, it will be connected to the remote connector (C) on the front of the machine.

Assembly of the Coolarc 20 or Coolarc 30

A Coolarc water-cooler can be mounted below the V205-T AC/DC or V305-T AC/DC and will convert the machine to a water-cooled system. Use a Coolarc 20 with the V205-T AC/DC and a Coolarc 30 with the V305-T AC/DC.

Disconnect the machine from the power line. On the V205-T AC/DC, remove the small excess door on the bottom of the machine and put the electrical plug of the Coolarc 20 in the connector. On the V305-T AC/DC, remove the left side panel of the machine and put the electrical plug of the Coolarc 30 in the connector located above the hole on the top shelf. Place the machine on top of the Coolarc and ensure the correct position in the prepared holes. Attach the machine to the Coolarc with the supplied screws.

Controls and Operational Features

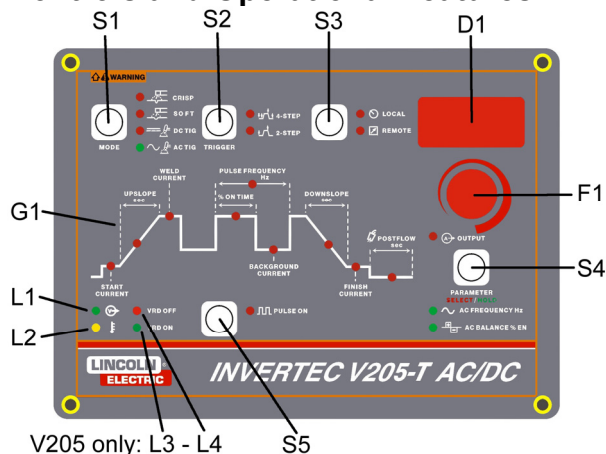

L1 - Voltage Warning Light: This green indicator is ON when the machine is switched ON with the main switch.

L2 - Safety Warning Light: This yellow indicator is ON when a thermal overheating or incorrect supply voltage error occurs. When this indicator is ON, an alarm code will flash on the display (D1). In this condition the machine does not supply power, the output is OFF. If a thermal overheating error occurs, leave the power

source ON and allow it to cool. Or, in the case of a supply voltage error, press any button to resume operation.

V205-T AC/DC only: L3, L4 - VRD (Voltage Reduction Device) Status Lights: Voltage reduction device can be enabled from the set-up menu and an output voltage limit can be set that reduces the output open circuit voltage when not welding to that limit. If enabled when the machine is sitting idle the Green VRD on light will illuminate to indicate the voltage is reduced below the set limit. If the VRD device is not enabled (factory default) from the set up menu or while welding the red VRD off light will illuminate. Enabling VRD will sacrifice stick welding performance when using E6010 type electrodes.

D1 - Display: Shows the welding current or the value of the welding parameter chosen with pushbutton S4. It is also used to display alarm or error messages and to adjust the set-up parameters.

F1 - Current and Function Control: Pre-setting of the welding current, welding parameters and set-up values. This allows you to continuously adjust the current both in TIG and in MMA welding. This current stays unchanged when the supply and welding conditions vary within the allowed ranges. In MMA welding, the presence of HOT-START and ARC-FORCE means that the average output current may be higher than that set at some stages of the welding process. Allows you to change the value, shown on the display (D1), of the parameter selected with pushbutton S4. Allows you to specify the required set-up line and to vary the value.

S1 - Mode Selection: Process selector. The LED beside the symbol will light up to confirm the selection: Stick Welding (V205-T AC/DC only: Soft Stick, Crisp Stick), DC TIG Welding, or AC TIG Welding.

S2 - Trigger Selection: Trigger mode selector. The LED beside the symbol will light up to confirm the selection: 4 Step operation or 2 Step operation. Refer to section below on TIG Trigger Sequences for a complete explanation of these operations.

S3 - Local/Remote Switch: Current control selector. The LED beside the symbol will light up to confirm the selection: Local Current Control (F1) or Remote Current Control.

S4 - Set-up/Parameter Switch: Allows entry into the set-up menu and parameter selection.

Parameter Selection

By pushing the pushbutton S4 (after the start up procedure) you can select the following TIG parameters:

- Start Current (A)
- Upslope Time (sec)
- Weld Current (A)
- Downslope Time (sec)
- Finish Current (A)
- Postflow Time (sec)

Press and hold the pushbutton S4 for 2 seconds to select the following AC parameters:

- AC/DC TIG Frequency (Hz)
- Wave Balance

AC Frequency

If the pushbutton S4 is held down for more than 2 seconds the AC frequency (Hz) parameter is selected and can be adjusted using the Current/Function Control (F1). Pushing the pushbutton S4 again in a short period of time, the AC balance (%) parameter is selected and can be adjusted again using the Current/Function Control (F1).

After few seconds without any changes, all the parameters are confirmed and the display D1 shows the welding current.

The parameter defaults and usable ranges are shown here.

Parameter	Value	Min	Max	Default
Start Current	A	8	Max	15
Upslope	Sec	0	10	0.2
Weld Current	A	6	Max	100
Downslope	Sec	0	10	1
Finish Current	A	6	Max	8
Post Flow	Sec	0.2	60	5
Frequency	Hz	0.1	500	0.5
Peak %	%	5	95	50
Background	A	1	Max	20
AC frequency	Hz	20	150	100
AC balance	%EN	35	85	65

Set-up Menu

To access the set-up menu start with the machine OFF. Press and hold the parameter selection button (S4) and turn the machine ON. In this mode you can now scroll through the set-up menu numbers using the current/function control (F1). Select a number in the menu you want to change, then press the parameter button (S4). Now you can change the values, using the current/function control (F1). When the desired values have been changed press the parameter selection button (S4) again to save the new value. To exit this set-up menu, use the current/function control (F1) to scroll through to 0 and press the parameter button (S4). The display then reverts back to the main current setting and normal operation is possible.

The following parameters can be adjusted.

V205-T AC/DC

	Parameter	Default
0	Exit from set-up	
2	Preflow Time (0-25 sec)	0.5 sec
3	Arc-Force Soft mode, percent above Peak Current for stick only (0-100%)	30%
4	Hot-Start Soft mode, percent above Peak Current for stick only (0-100%)	80%
5	Arc-Force Crisp mode, percent above Peak Current for stick only (0-500%)	350%
6	Hot-Start Crisp mode, percent above Peak Current for stick only (0-500%)	150%
7	Setting the AC Waveform 0 = Sinusoidal 1 = Triangular 2 = Square	2
8	VRD Off = Disabled 1 = Enabled (limits OCV to 12V) 2 = Enabled (limits OCV to 20V) 3 = Enabled (limits OCV to 32V)	Off
9	Max current value with Remote Control (6 A - Peak current)	Peak Current
10	Lift or HF start in DC, ignored in AC HF starting Lift starting	HF

11	Reset of all Parameters	
12	DC TIG Strike Current 6-200A	30A
13	DC TIG Start Polarity 0 = DC- 1 = DC+	1
14	2 Step trigger selection 0 = restart disabled 1 = restart enabled	0
15	4 Step trigger selection 0 = restart disabled 1 = restart enabled	1
16	AC Start Power (For AC TIG only) This function sets the initial start energy limit. Set this number to a higher setting than the factory default if needed to improve starting of large diameter tungsten electrodes. 0.5 to 1.0 = manual start energy setting 1.2 to 5.0 = max. incrementing limit (*) (* The machine will try to start the machine at a start power of 1. If the arc does not establish it will incrementally increase the start power and try to restrike up to the set limit.	2
17	TIG Pulsed Base Current Setting: 0 = Absolute value setting 1 = Percentage value setting	1

V305-T AC/DC

	Parameter	Default
0	Exit from set-up	
2	Preflow Time (0-25 sec)	0.5 sec
3	Arc-Force, percent above Peak Current for stick only (0-100%)	30%
4	Hot-Start, percent above Peak Current for stick only (0-100%)	80%
5	Setting the AC Waveform 0 = Sinusoidal 1 = Triangular 2 = Square	2
6	Min current value with Remote Control (6 A - Peak current)	10 A
7	Max current value with Remote Control (6 A - Peak current)	Peak Current
8	Lift or HF start in DC, ignored in AC 0 = HF starting 1 = Lift starting	0
9, 10, 11	Do not select or modify, used for factory settings.	
12	2 Step trigger selection 0 = restart disabled 1 = restart enabled	0
13	4 Step trigger selection 0 = restart disabled 1 = restart enabled	1
14	Electrode selection for TIG only (increase positive half wave ignition)	2.0

S5 - Pulse ON/OFF: The LED beside the symbol will light up to confirm the selection: Pulse ON or OFF.

The led on the graphic display is indicating the function and the display will show the parameter. You may select the function by pushing the parameter button (S4) and adjust the setting with the current/function control (F1).

- Frequency
- Pulse on time
- Background current

TIG Trigger Sequences

TIG welding can be done in either the 2-step or 4-step mode, which is selected with the Trigger Selection

button. The specific sequences of operation for these two trigger modes are explained below.

2-Step TIG Sequence

With the 2-step trigger mode and a TIG welding mode selected, the following welding sequence will occur. To setup the machine for TIG welding refer to the Output Connections section.

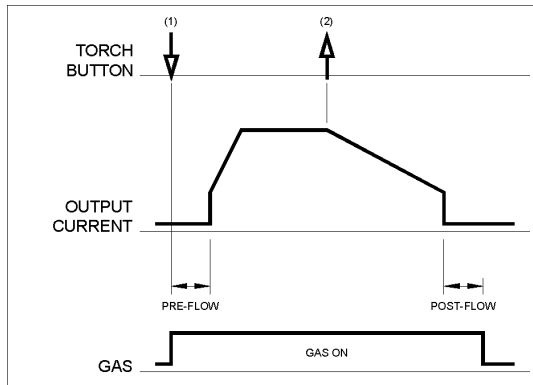

1. Press and hold the TIG torch trigger to start the sequence. The machine will open the gas valve to start the flow of the shielding gas. After the preflow time, to purge air from the torch hose, the output of the machine is turned ON. At this time the arc is started according to the selected welding mode (Lift TIG or HF TIG). The default setting is HF starting and can be changed to Lift TIG in the set-up menu.

After the arc is started the output current will be increased to the welding current. This increase or upslope time will be dependent on the times you have selected using the Parameter Selector switch.

2. Release the TIG torch trigger to stop welding. The machine will now decrease the output current at a controlled rate, or downslope time, until the Start/Crater current is reached and the output of the machine is turned OFF. The Downslope Control adjusts the downslope time.

After the arc is turned OFF, the gas valve will remain open to continue the flow of the shielding gas to the hot electrode and work piece. The Postflow Control adjusts the duration of this postflow shielding gas time.

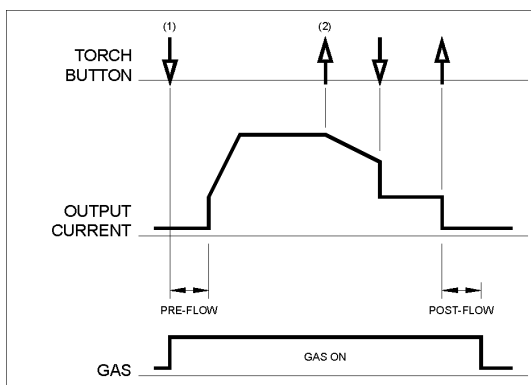

As shown above, it is possible to press and hold the TIG torch trigger a second time during downslope to end the downslope time and maintain the output current at the Start/Crater current. When the TIG torch trigger is

released the output will turn OFF and the postflow time will start.

The default setting is restart disabled. Restart enabled can be selected in the set-up menu.

4-Step Sequence

With the 4-step trigger mode and a TIG welding mode selected, the following welding sequence will occur. To setup the machine for TIG welding refer to the Output Connections section.

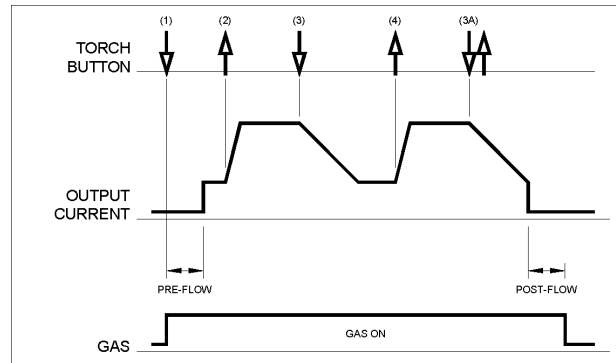

1. Press and hold the TIG torch trigger to start the sequence. The machine will open the gas valve to start the flow of the shielding gas. After the preflow time, to purge air from the torch hose, the output of the machine is turned ON. At this time the arc is started according to the selected welding mode (Lift TIG or HF TIG). The default setting is HF starting and can be changed to Lift TIG in the set-up menu.

After the arc is started the output current will be at the Start/Crater current. This condition can be maintained as long or as short as necessary (search arc facility).

If the Start/Crater current is not necessary, do not hold the TIG torch trigger as described at the beginning of this step. Instead, quickly press and release it. In this condition, the machine will automatically pass from Step 1 to Step 2 when the arc is started.

2. Releasing the TIG torch trigger starts the upslope function. The time is dependant on the upslope time you have selected using the Parameter Selector switch. The output current will be increased to the set welding current.
3. Press and hold the TIG torch trigger when the main part of the weld is complete. The machine will now decrease the output current at a controlled rate, or downslope time, until the Start/Crater current is reached. The Downslope time is dependant on the time that has been set using Parameter Selection switch. This finish/Crater current can be maintained as long or as short as necessary.

This sequence has an automatic restart so welding will continue after this step. If the weld is completely finished, use the following sequence instead of step 3 described above.

- 3A. Quickly press and release the TIG torch trigger. The machine will now decrease the output current at a controlled rate, or downslope

time, until the Start/Crater current is reached and the output of the machine is turned OFF. After the arc is turned OFF the postflow time will start.

4. Release the TIG torch trigger. The output current will again increase to the welding current, like in step 2, to continue welding. When the main part of the weld is complete go to step 3.

As shown here, after the TIG torch trigger is quickly pressed and released from step 3A, it is possible to press and hold the TIG torch trigger another time to end the downslope time and maintain the output current at the Start/Crater current. When the TIG torch trigger is released the output will again increase to the welding current, like in step 4, to continue welding. When the main part of the weld is complete go to step 3.

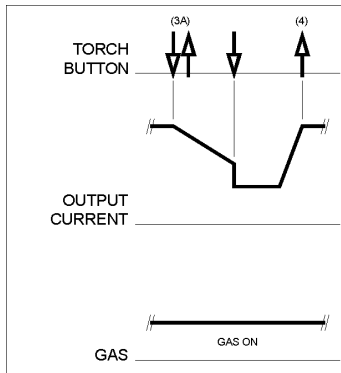

As shown here, again after the TIG torch trigger is quickly pressed and released from step 3A, it is possible to quickly press and release the TIG torch trigger a second time to end the downslope time and stop welding.

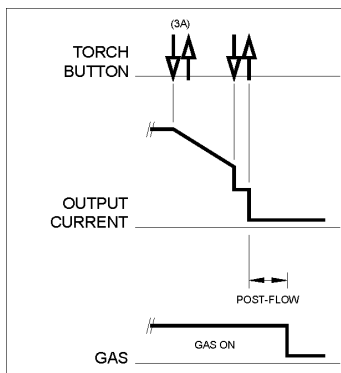

The default setting is restart enabled. Restart disabled can be selected in the set-up menu.

Maintenance

WARNING

For any maintenance or repair operations it is recommended to contact the nearest technical service center or Lincoln Electric. Maintenance or repairs performed by unauthorized service centers or personnel will null and void the manufacturers warranty.

The frequency of the maintenance operations may vary in accordance with the working environment. Any noticeable damage should be reported immediately.

- Check cables and connections integrity. Replace, if necessary.
- Keep clean the machine. Use a soft dry cloth to clean the external case, especially the airflow inlet / outlet louvers.

WARNING

Do not open this machine and do not introduce anything into its openings. Power supply must be disconnected from the machine before each maintenance and service. After each repair, perform proper tests to ensure safety.

Electromagnetic Compatibility (EMC)

11/04

This machine has been designed in accordance with all relevant directives and standards. However, it may still generate electromagnetic disturbances that can affect other systems like telecommunications (telephone, radio, and television) or other safety systems. These disturbances can cause safety problems in the affected systems. Read and understand this section to eliminate or reduce the amount of electromagnetic disturbance generated by this machine.



This machine has been designed to operate in an industrial area. To operate in a domestic area it is necessary to observe particular precautions to eliminate possible electromagnetic disturbances. The operator must install and operate this equipment as described in this manual. If any electromagnetic disturbances are detected the operator must put in place corrective actions to eliminate these disturbances with, if necessary, assistance from Lincoln Electric.

Before installing the machine, the operator must check the work area for any devices that may malfunction because of electromagnetic disturbances. Consider the following.

- Input and output cables, control cables, and telephone cables that are in or adjacent to the work area and the machine.
- Radio and/or television transmitters and receivers. Computers or computer controlled equipment.
- Safety and control equipment for industrial processes. Equipment for calibration and measurement.
- Personal medical devices like pacemakers and hearing aids.
- Check the electromagnetic immunity for equipment operating in or near the work area. The operator must be sure that all equipment in the area is compatible. This may require additional protection measures.
- The dimensions of the work area to consider will depend on the construction of the area and other activities that are taking place.

Consider the following guidelines to reduce electromagnetic emissions from the machine.

- Connect the machine to the input supply according to this manual. If disturbances occur it may be necessary to take additional precautions such as filtering the input supply.
- The output cables should be kept as short as possible and should be positioned together. If possible connect the work piece to ground in order to reduce the electromagnetic emissions. The operator must check that connecting the work piece to ground does not cause problems or unsafe operating conditions for personnel and equipment.
- Shielding of cables in the work area can reduce electromagnetic emissions. This may be necessary for special applications.

Technical Specifications

V205-T AC/DC:

INPUT			
Input Voltage 115/230 V ± 15% Single Phase	Input Power at Rated Output 6.6 kW @ 40% Duty Cycle	Frequency 50/60 Hz	
RATED OUTPUT AT 40°C			
Duty Cycle (Based on a 10 min. period) 40% TIG 115/230 V 60% TIG 115/230 V 35% MMA 115/230 V 60% MMA 115/230 V	Output Current 150/200 A 120/170 A 110/180 A 90/150 A	Output Voltage 16.0/18.0 Vdc 14.8/16.8 Vdc 24.4/27.2 Vdc 23.6/26.0 Vdc	
OUTPUT RANGE			
Welding Current Range 6-200 A		Maximum Open Circuit Voltage 53.7 Vdc	
RECOMMENDED INPUT CABLE AND FUSE SIZES			
Fuse or Circuit Breaker Size 16 A Superlag	Type of Plug SCHUKO 16A/250V (Included with Machine)	Input Power Cable 3 Conductor, 2.5 mm ²	
PHYSICAL DIMENSIONS			
Height 385 mm	Width 215 mm	Length 480 mm	Weight 17.6 Kg
Operating Temperature -20°C to +40°C		Storage Temperature -25°C to +55°C	

V305-T AC/DC:

INPUT			
Input Voltage 400 V ± 15% Three Phase	Input Power at Rated Output 11.8kW @ 40% Duty Cycle	Frequency 50/60 Hz	
RATED OUTPUT AT 40°C			
Duty Cycle (Based on a 10 min. period) 40% 60%	Output Current 300 A 250 A	Output Voltage 32.0 Vdc 30.0 Vdc	
OUTPUT RANGE			
Welding Current Range 6-300 A		Maximum Open Circuit Voltage 81 Vdc	
RECOMMENDED INPUT CABLE AND FUSE SIZES			
Fuse or Circuit Breaker Size 20 A Superlag		Input Power Cable 4 Conductor, 6 mm ²	
PHYSICAL DIMENSIONS			
Height 500 mm	Width 275 mm	Length 610 mm	Weight 33 Kg
Operating Temperature -20°C to +40°C		Storage Temperature -25°C to +55°C	

Accessories, Accessori, Zubehör, Accesorios, Accessoires, Tilleggsutstyr, Accessores, Tillbehör, Akcesoria, Varusteet

W6100316R	<p>Trigger Connector (5 pins). Connettore per pulsante torcia. Tuchelstecker (5-polig) für Brenntaster. Conector de señal de pulsador. Prise mâle gâchette (5 broches). Kontakt for avtrekker (5 pol tuchel). Connector voor toortsschakelaar. Avtryckarkontakt. Łącznik przycisku startowego. Liipaisinliitäntä 5 nastaa.</p>
W6100317R	<p>Remote Connector (6 pins). Connettore per comando a remoto. Amphenolstecker (6 polig) für Fernregler. Conector de señal de control remoto. Prise mâle commande à distance (6 broches). Kontakt for fjernkontrol. Connector voor afstandbediening. Kontakt för fjärrkontroll. Łącznik zdalnego sterowania. Kaukosäätöliitäntä 6 napaa.</p>
W8800072R	<p>Male Quick Connect Gas Fitting. Giunto ad innesto rapido per gas, maschio. Gas-Schnellkupplung, männlich. Conector rápido macho para gas. Connecteur rapide mâle gaz. Hurtigkobling gass (Han). Snelkoppeling voor gasaansluiting. Snabbkoppling hane för gas. Męska końcówka szybkozłączki gazowej. Naaras kaasupikaliitin.</p>
K10095-1-15M	<p>Hand Amptrol. Comando a distanza manuale. Handfernregler. Control remoto. Commande à distance à main. Fjernregulator hånd. Hand afstandbediening. Fjärrkontroll hand. Ręczny regulator prądu. Käsikaukosäädin.</p>
K870	<p>Foot Amptrol. Comando a distanza a pedale. Fußpedalfernregler. Amptrol Pedal. Commande à distance à pied. Fotregulator. Voet afstandbediening. Fjärrkontroll pedal. Nożny regulator prądu. Jalkakaukosäädin.</p>
K1904-1 (V205-T AC/DC)	<p>Coolarc 20 Water Cooler. Gruppo di raffreddamento Coolarc 20. Coolarc 20 Wasserkühler. Refrigerador Coolarc 20. Refroidisseur Coolarc 20. Coolarc 20 kjøleaggregat. Coolarc 20 waterkoeler. Coolarc 20 kylaggregat. Chłodnica wodna Coolarc 20. Coolarc 20 vesijäähdytin.</p>

K2168-1 (V305-T AC/DC)	Coolarc 30 Water Cooler. Gruppo di raffreddamento Coolarc 30. Coolarc 30 Wasserkühler. Refrigerador Coolarc 30. Refroidisseur Coolarc 30. Coolarc 30 kjøleaggregat. Coolarc 30 waterkoeler. Coolarc 30 kylaggregat. Chłodnica wodna Coolarc 30. Coolarc 30 vesijäähdytin.
W0200002 (V205-T AC/DC)	Undercarriage with cylinder holder. Carrello con portabombola. Fahrwagen mit Zylinder-Halter. Carro para Inverter TIG 2 ruedas. Chariot porte-bouteille, 2 roues, type "diable". Tralle med flaskeholder. Transportwagen met flessendrager. Vagn med hållare för gasflaska. Wózek z półką na butle gazową. Vaunu pullopitimellä.
W0200003 (V305-T AC/DC)	Undercarriage with cylinder holder. Carrello con portabombola. Fahrwagen mit Zylinder-Halter. Carro para Inverter TIG 4 ruedas. Chariot 4 roues. Tralle med flaskeholder. Transportwagen met flessendrager. Vagn med hållare för gasflaska. Wózek z półką na butle gazową. Vaunu pullopitimellä.
GRD-200A-35-5M (V205-T AC/DC) GRD-300A-50-5M (V305-T AC/DC)	Welding work lead. Cavo massa. Massekabel. Cable de masa. Câble de masse. Jordingskabel med godslemme. Massakabel. Återledare. Przewód masowy z zaciskiem. Maattokaapeli.
KIT-200A-35-5M (V205-T AC/DC) KIT-300A-50-5M (V305-T AC/DC)	Welding kit cables. Kit cavi di saldatura. E-Handleitung. Kit cables de soldadura. Kit accessoires. Sveisekabelsett. Lassetvoor. Svetskablar. Kompolet przewodów spawalniczych. Hitsauskaapelisarja.
W0400068A	TIG torch (air), 4m. Torcia TIG (aria), 4m. WIG-Brenner (luftgekühlt), 4m. Pistola TIG (gas) 4m. Torche TIG (air), 4m. TIG sveisepistol 4m luftkjølt. Tigtoorts (luchtgekoeld) 4 meter. TIG-brännare (luft), 4 m. Uchwyt spawalniczy TIG (chł. gazem), 4m. TIG poltin (ilma), 4 m.

W0400068A-8	<p>TIG torch (air), 8m. Torcia TIG (aria), 8m. WIG-Brenner (luftgekühlt), 8m. Pistola TIG (gas) 8m. Torche TIG (air), 8m. TIG sveisepistol 8m luftkjølt Tigtoorts (luchtgekoeld) 8 meter TIG-brännare (luft), 8 m. Uchwyt spawalniczy TIG (chł. gazem), 8m. TIG poltin (ilma), 8 m.</p>
W0400069A	<p>TIG torch (cooled), 4m. Torcia TIG (raffreddata acqua), 4m. WIG-Brenner (wassergekühlt), 4m. Pistola TIG (refrigerada por agua) de 4m. Torche TIG (refroidie eau), 4m. TIG sveisepistol 4m vannkjølt. Tigtoorts watergekoeld 4 meter. TIG-brännare (kyld), 4 m. Uchwyt spawalniczy TIG (chł. cieczą), 4m. TIG poltin (jäähdytetty), 4 m.</p>
W0400069A-8	<p>TIG torch (cooled), 8m. Torcia TIG (raffreddata acqua), 8m. WIG-Brenner (wassergekühlt), 8m. Pistola TIG (refrigerada por agua) 8m. Torche TIG (refroidie eau), 8m. TIG sveisepistol 8m vannkjølt. Tigoorts watergekoeld 8 meter. TIG-brännare (kyld), 8 m. Uchwyt spawalniczy TIG (chł. cieczą), 8m. TIG poltin (jäähdytetty), 8 m.</p>
W0400026A	<p>Automatic TIG torch (cooled), 4m. Torcia TIG automatica (raffreddata acqua), 4m. Maschinen-WIG-Brenner (wassergekühlt), 4m. Pistola TIG automática (refrigerada por agua) 4m. Torche TIG automatique (refroidie eau), 4m. Automatisk TIG sveisepistol 4m vannkjølt. Tigtoorts Automaat 4 meter. Automatisk TIG-brännare (kyld), 4m. Uchwyt maszynowy TIG (chł. cieczą), 4m. Automaatti TIG poltin (jäähdytetty), 4 m.</p>
LE250Z002	<p>Gas reducer with column flux-meter, 16lt. Riduttore gas con flussometro a colonnina, 16lt. Druckminderer, 16lt. Flotámetro, 16 litros. Réducteur de débit de gaz. Gassregulator med flowmeter 16lt. Reduceerventiel met flowmeter. Gasregulator med flödesrör, 16 L Reduktor gazu z rotametrem, 16lt. Kaasusäädin, pylväsmittari, 16lt.</p>